

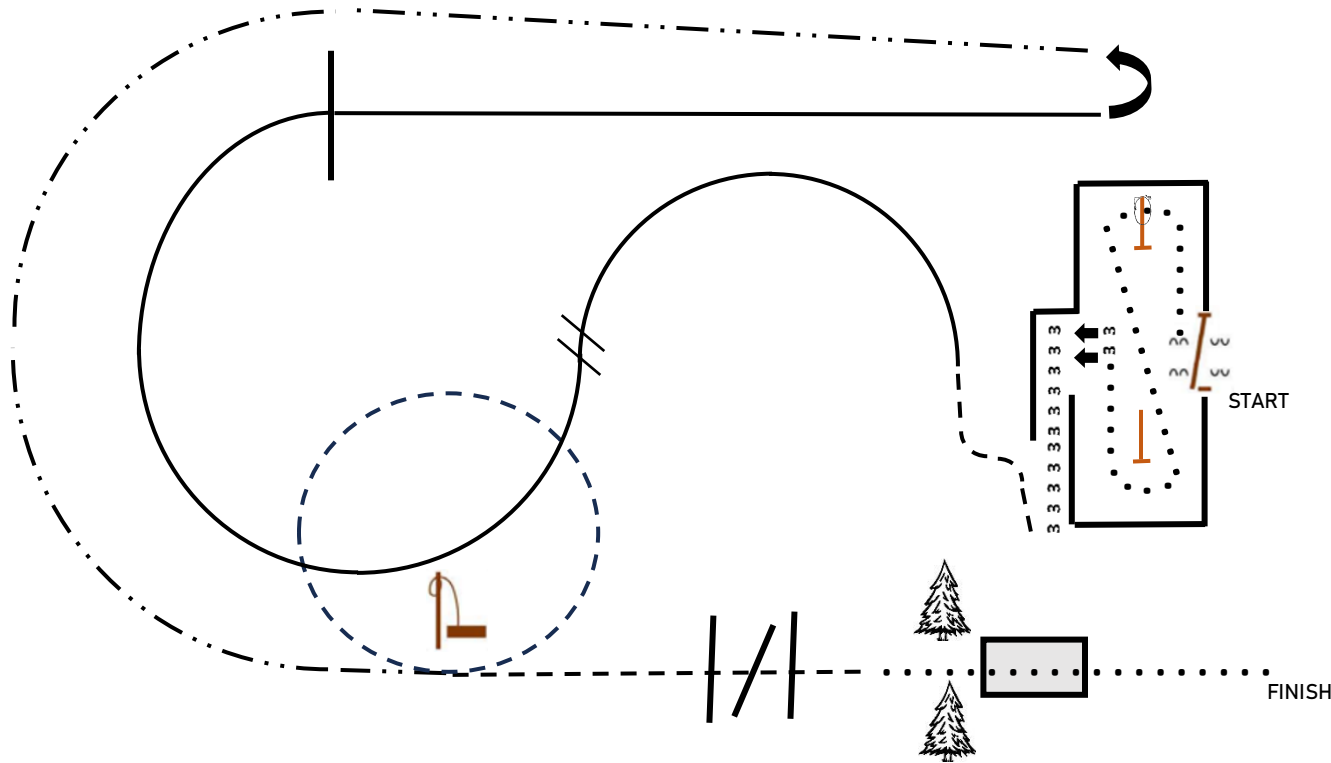

Band City AQHA & APHA Show

May 17th, 2024

All Ranch Trail



BE READY AT GATE.
 WORK GATE, RH.
 WALK TO 1st POST & PICK UP ROPE.
 WALK TO 2nd POST & HANG ROPE.
 SIDEPASS LEFT.
 BACK OUT OF OBSTACLE.
 JOG.
 LOPE LL.
 SIMPLE OR FLYING LEAD CHANGE.
 LOPE RL OVER LOG.
 ROLL BACK.
 EXTENDED JOG TO DRAG.
 DRAG AROUND POST AT WALK OR JOG.
 JOG OVER LOGS.
 WALK OVER BRIDGE TO FINISH

WALK
JOG	-----
LOPE	————
EXT. JOG	— . . —
BACK	3 3 3 3 3

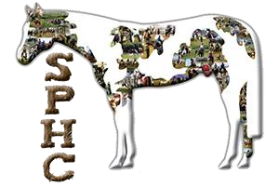

Band City AQHA & APHA Show

May 18th, 2024

Am, Am Sel, Yth, Jr, Sr, Yth SPB,
SPB, Am SPB

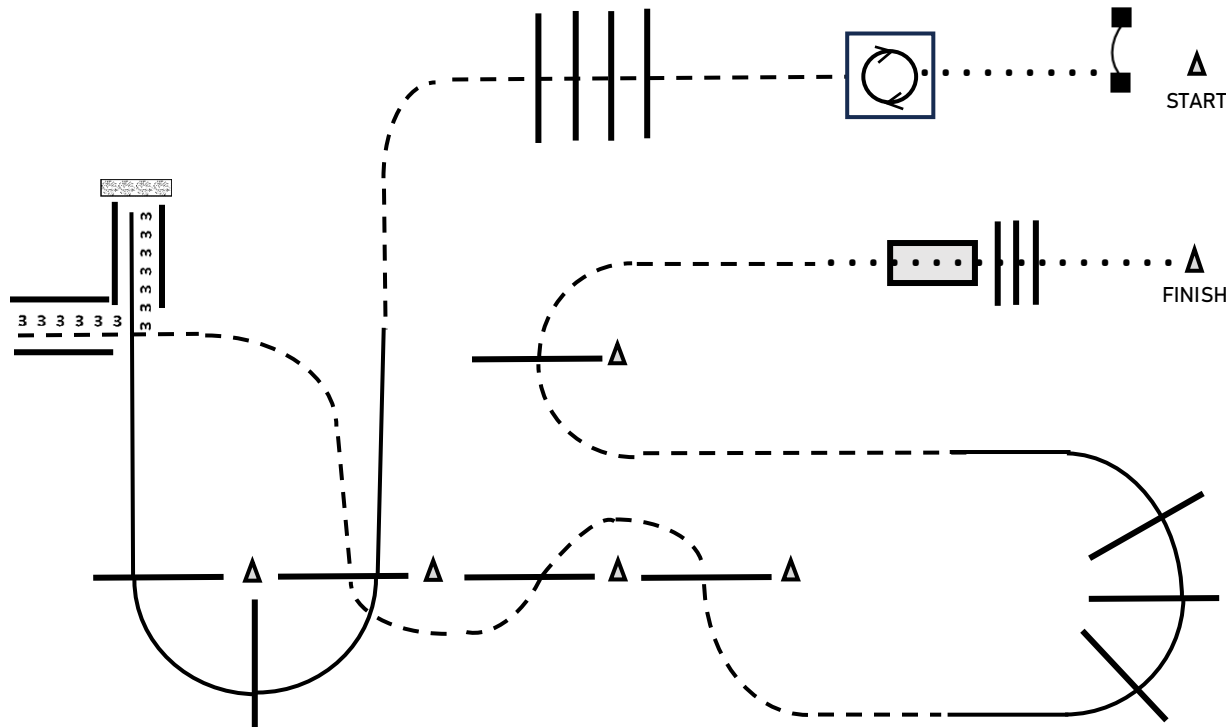

BE READY AT GATE.
WORK GATE, LH.
WALK INTO BOX.
360° RIGHT.
JOG OVER POLES.
LOPE OVER POLES & INTO CHUTE, RL.
BACK L.
JOG OVER POLES/SERPENTINE.
LOPE OVER POLES, LL.
JOG AROUND CONE AND OVER POLE.
WALK OVER BRIDGE AND POLES TO FINISH.

WALK
JOG	-----
LOPE	—————
BACK	3 3 3 3 3



Band City AQHA & APHA Show

May 18th, 2024

L1 Open, L1 yth, L1 am, Nov yth,
Nov am, Green

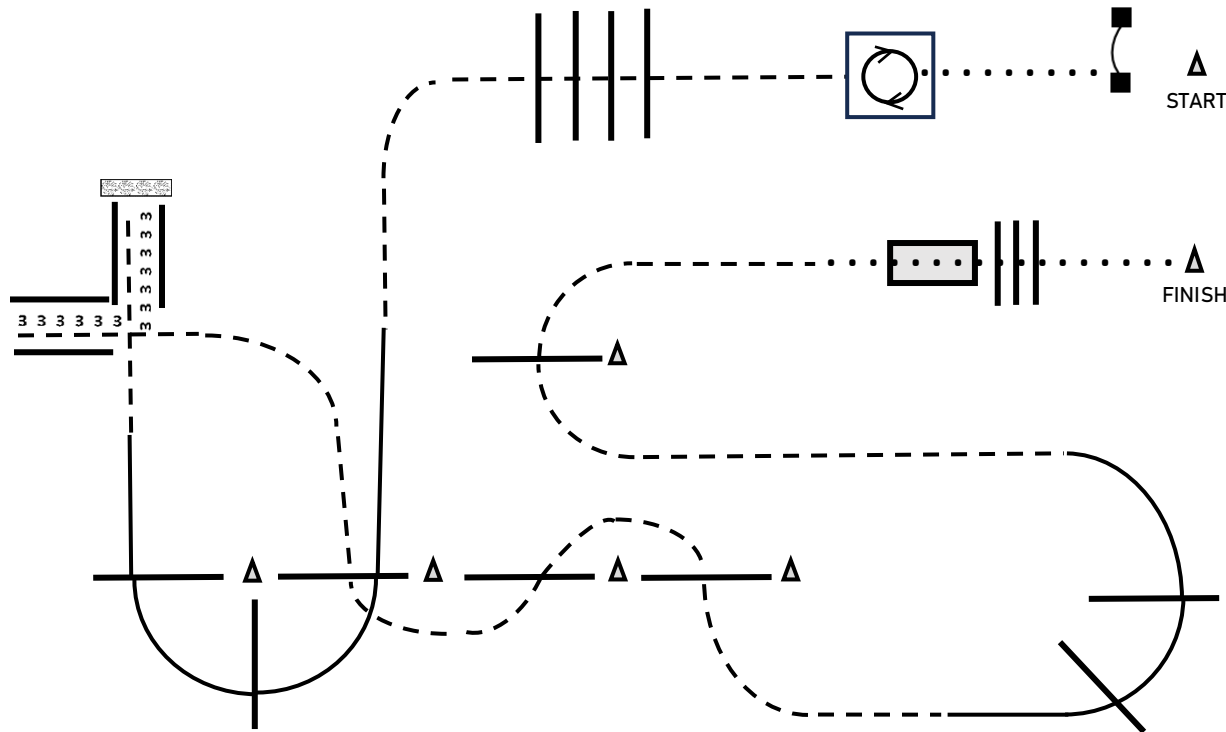

BE READY AT GATE.
WORK GATE, LH.
WALK INTO BOX.
360° RIGHT.
JOG OVER POLES.
LOPE OVER POLES, RL.
JOG INTO CHUTE.
BACK L.
JOG OVER POLES/SERPENTINE.
LOPE OVER POLES, LL.
JOG AROUND CONE AND OVER POLE.
WALK OVER BRIDGE AND POLES TO FINISH.

WALK
JOG	-----
LOPE	————
BACK	3 3 3 3 3

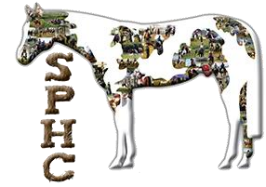

Band City AQHA & APHA Show

May 18th, 2024

All Walk/Jog and Trail in Hand

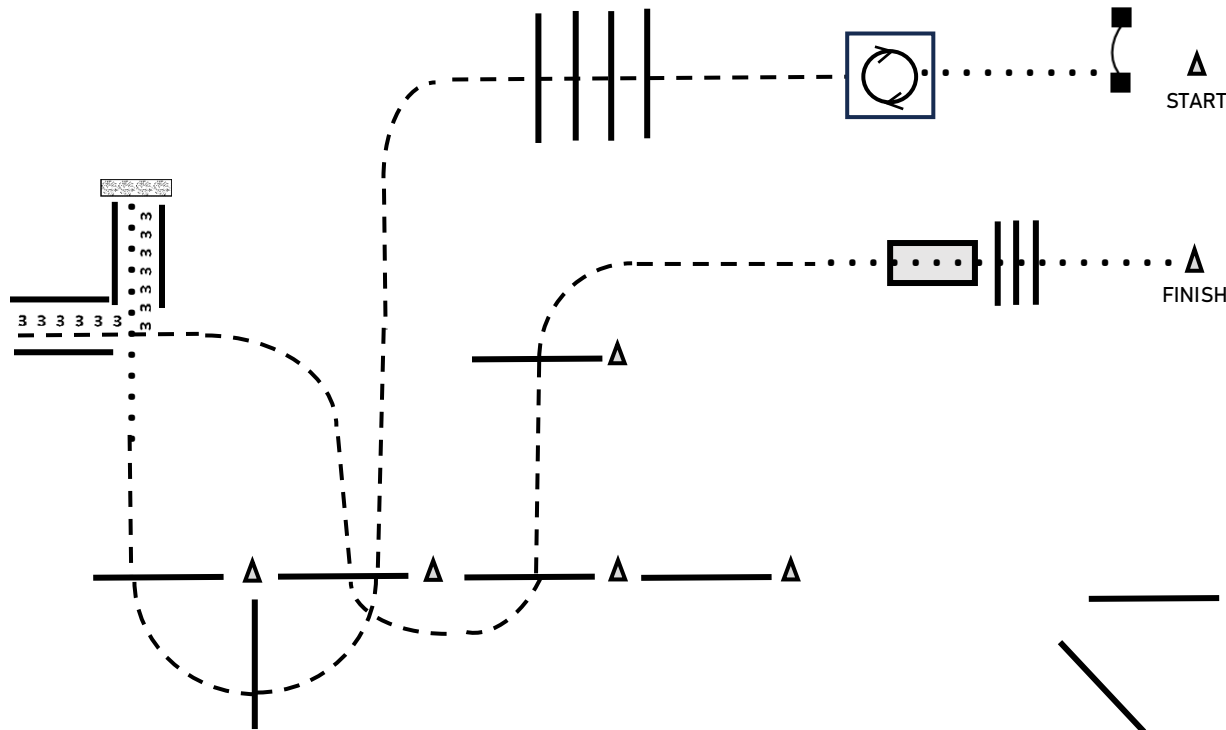

BE READY AT GATE.
 WORK GATE, LH.
 WALK INTO BOX.
 360° RIGHT.
 JOG OVER POLES.
 WALK INTO CHUTE.
 BACK L.
 JOG OVER POLES & AROUND CONES.
 WALK OVER BRIDGE AND POLES TO FINISH.

WALK
JOG	-----
LOPE	—————
BACK	3 3 3 3 3 3



Band City AQHA & APHA Show

May 19th, 2024

All Ranch Trail

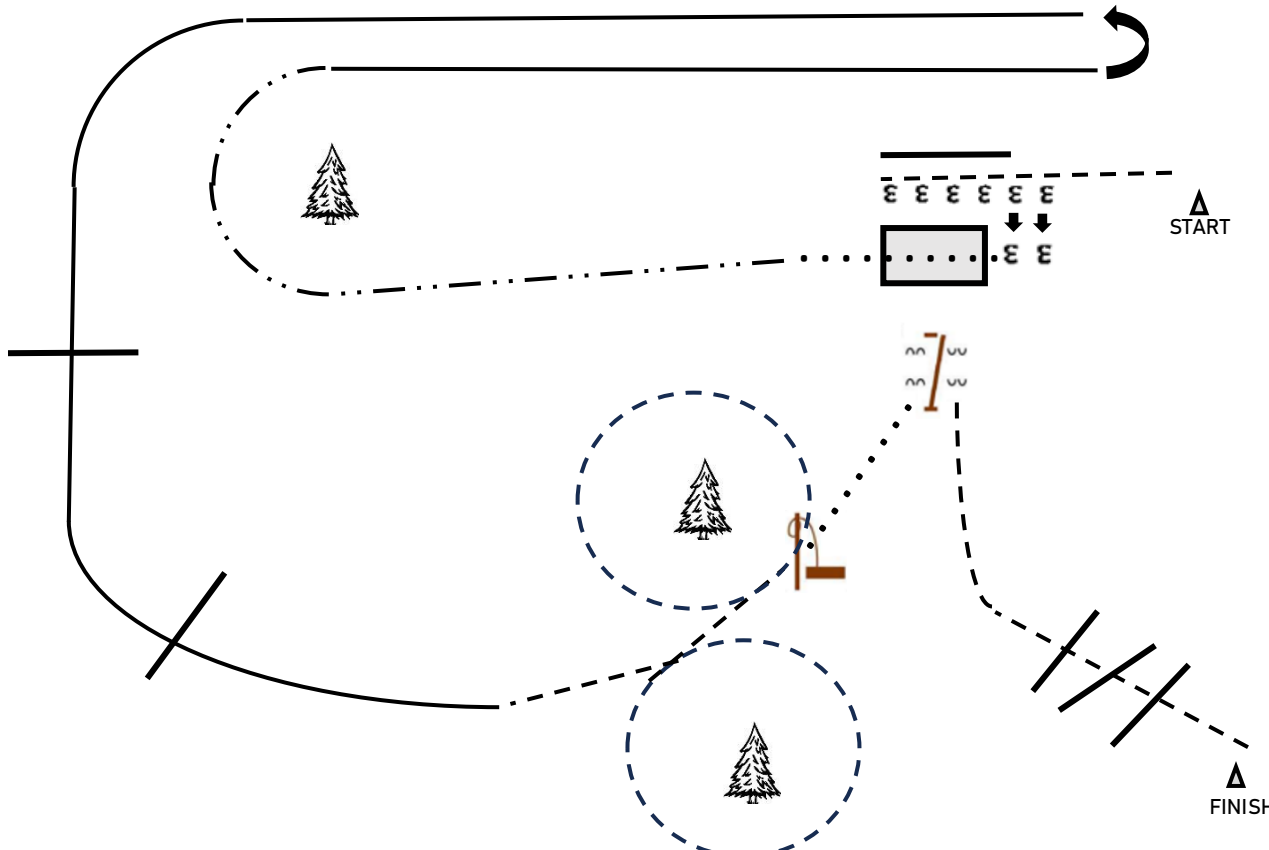

BE READY AT CONE.
 JOG INTO CHUTE.
 BACK CHUTE.
 SIDEPASS RIGHT.
 WALK OVER BRIDGE.
 EXTENDED JOG AROUND TREE.
 LOPE RL.
 ROLL BACK.
 LOPE LL OVER LOGS.
 JOG AROUND TREE.
 STOP AT DRAG OBSTACLE.
 DRAG LOG AROUND TREE & RETURN TO POST.
 WALK TO GATE.
 WORK GATE, RH.
 TROT OVER LOGS TO FINISH.

WALK
JOG	-----
LOPE	————
EXT. JOG	- . - . - .
BACK	3 3 3 3 3

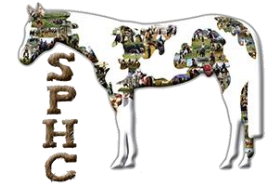

Band City AQHA & APHA Show

May 20th, 2024

Am, Am Sel, Yth, Jr, Sr, Yth SPB,
 SPB, Am SPB

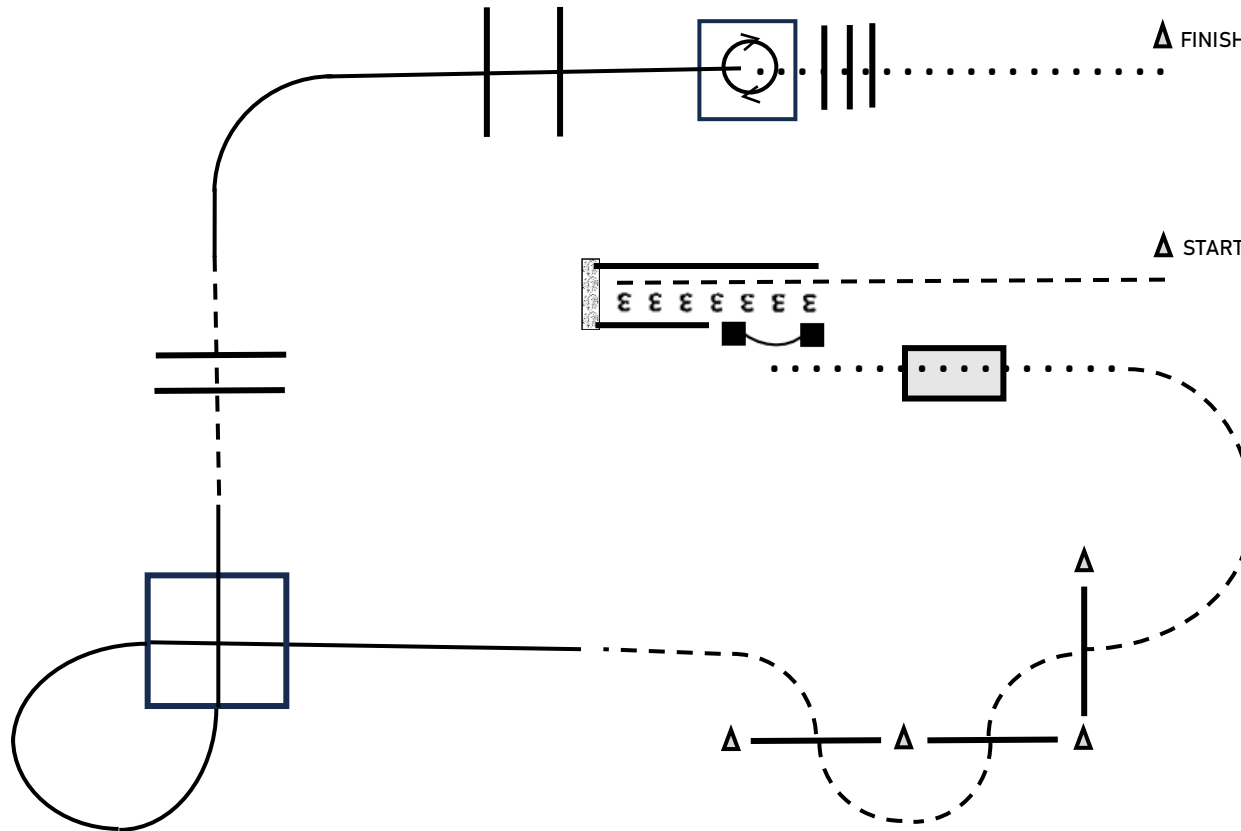

BE READY AT CONE.
 JOG INTO CHUTE.
 BACK TO GATE.
 WORK GATE, LH.
 WALK OVER BRIDGE.
 JOG OVER POLES & AROUND CONES.
 LOPE OVER 12' BOX, LL.
 JOG POLES.
 LOPE OVER POLES AND INTO 10' BOX, RL.
 360° RIGHT.
 WALK OVER POLES TO FINISH.

WALK
JOG	-----
LOPE	————
BACK	3 3 3 3 3

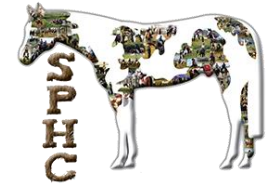

Band City AQHA & APHA Show

May 20th, 2024

L1 Open, L1 yth, L1 am, Nov yth,
Nov am, Green

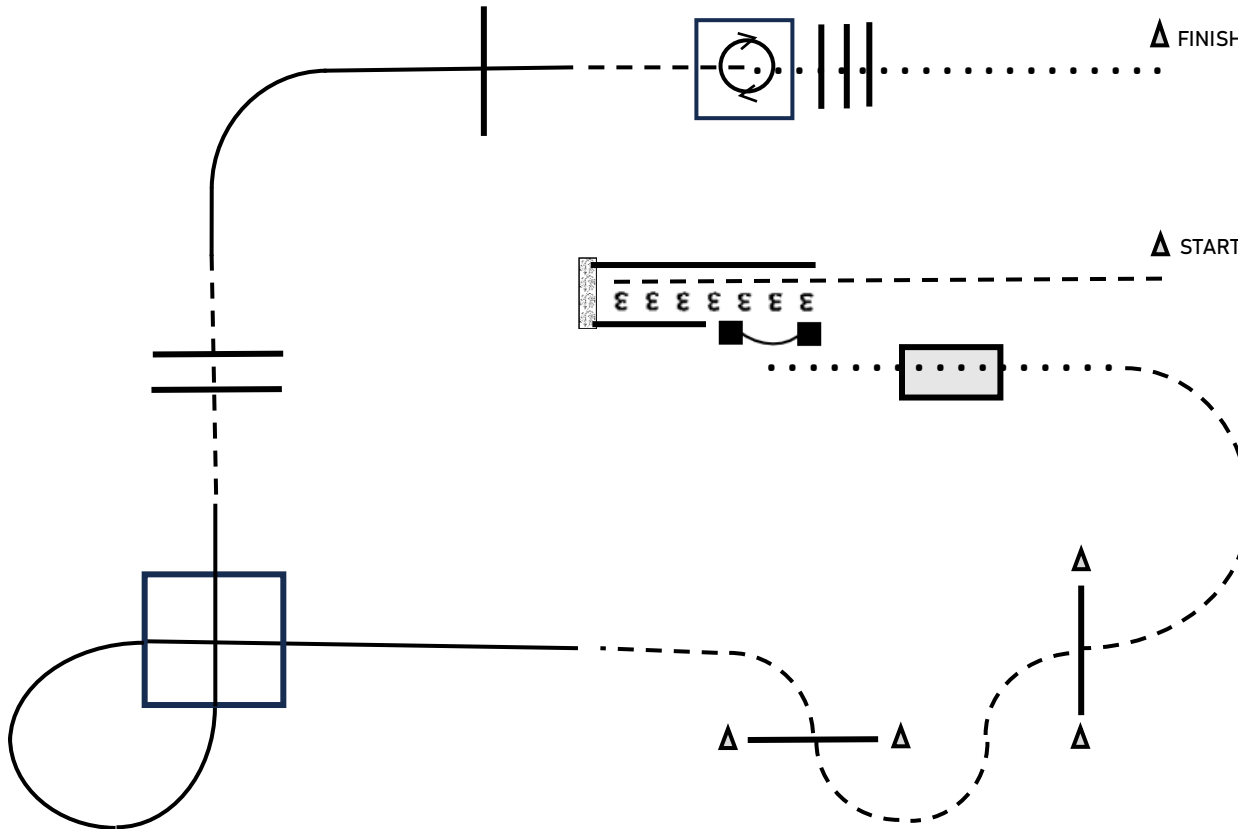

BE READY AT CONE.
JOG INTO CHUTE.
BACK TO GATE.
WORK GATE, LH.
WALK OVER BRIDGE.
JOG OVER POLES & AROUND CONES.
LOPE OVER 12' BOX, LL.
JOG POLES.
LOPE OVER POLE.
JOG INTO 10' BOX.
360° RIGHT.
WALK OVER POLES TO FINISH.

WALK
JOG	-----
LOPE	—————
BACK	3 3 3 3 3



Band City AQHA & APHA Show

May 20th, 2024

All Walk/Jog and Trail in Hand

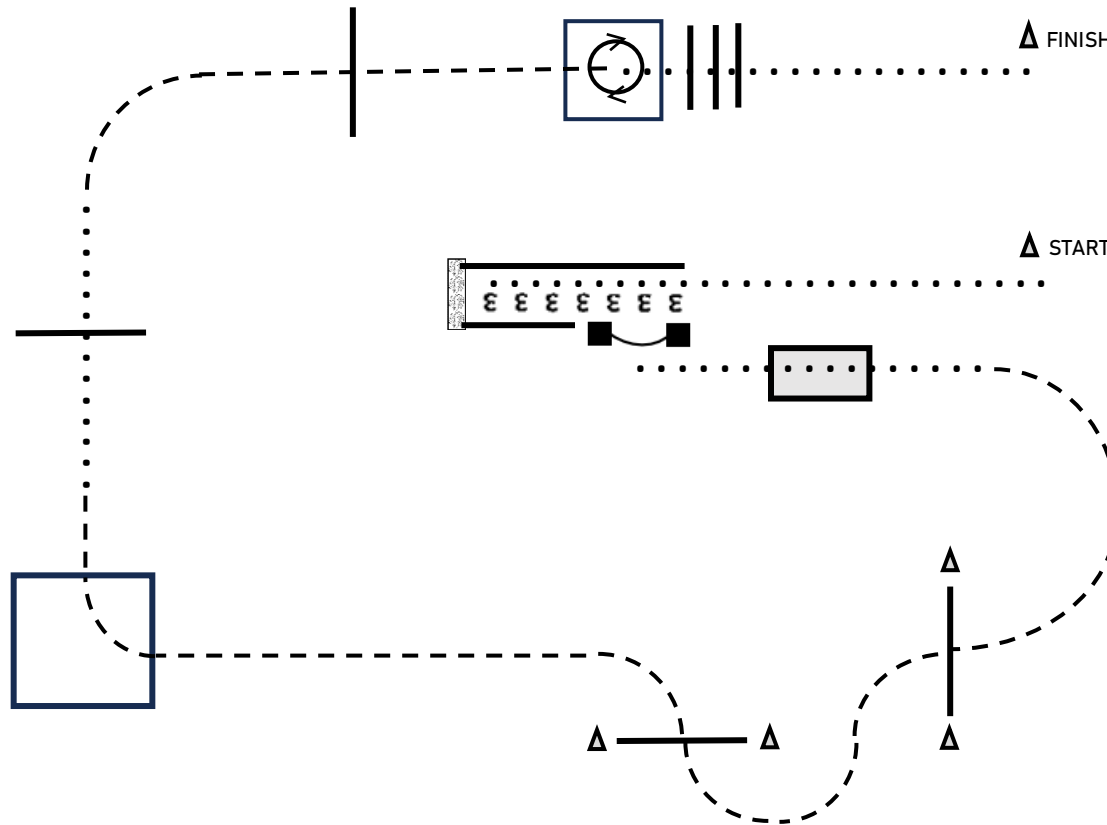

BE READY AT CONE.
 WALK INTO CHUTE.
 BACK TO GATE.
 WORK GATE, LH.
 WALK OVER BRIDGE.
 JOG OVER POLES & AROUND CONES.
 JOG THROUGH 12' BOX.
 WALK OVER POLE.
 JOG OVER POLE & INTO 10' BOX.
 360° RIGHT.
 WALK OVER POLES TO FINISH.

WALK
JOG	-----
LOPE	—————
BACK	3 3 3 3 3 3